



DJ Gongol & Associates, Inc.

PO Box 180 | West Des Moines, IA 50061-0180
4328 North Dawson | Cumming, IA 50061
515-223-4144 | 515-981-0581 fax
info@gongol.net

VENT-O-MAT[®]

SERIES RGXII

“ANTI-SURGE”

SEWAGE AIR RELEASE AND VACUUM BREAK VALVES

**FOR EFFECTIVE AIR RELEASE, VACUUM PROTECTION AND
SURGE ALLEVIATION**



RF Valves, Inc. / Vent-O-Mat USA

1342 Charwood Road
Suite A
Hanover
MD 21076
USA

Phone: +1-410-850-4404

Fax: +1-410-850-4464

E-mail: rfq@rfvalve.com

web: www.rfvalve.com



Revision Date August 2015 Catalogue RGXII0003



CATALOGUE INDEX

- **Introduction** **Page 1**
- **Recommended Installation Arrangements** **Page 2**
- **Operation** **Page 3**
- **Available Discharge Connections** **Page 4**
- **Component Description & Material Specification** **Page 5**
Epoxy Coated Cast Body -
Flanged Inlet 2" to 8"
- **General Specifications** **Page 6**
Epoxy Coated Cast Body -
Flanged Inlet 2" to 8"
- **Component Description & Material Specification** **Page 7**
Full Stainless Steel Body -
Threaded Inlet 2" and Flanged Inlet 2" to 8"
- **General Specifications** **Page 8**
Full Stainless Steel Body -
Threaded Inlet 2" and Flanged Inlet 2" to 8"
- **Small Orifice Discharge Performance** **Page 9**
- **Selection and Positioning** **Pages 10 & 11**
- **Surge and Water Hammer Protection** **Page 12**
- **Purchase Specification** **Page 13**
- **Ordering Guide** **Page 14**



DJ Gongol & Associates, Inc.

PO Box 180 | West Des Moines, IA 50061-0180
4328 North Dawson | Cumming, IA 50061
515-223-4144 | 515-981-0581 fax
info@gongol.net

Series RGXII INTRODUCTION

- **DESIGN** - the RGXII has been designed owing to customer demand. When taking into account customer requests that influenced the design, key benefits which Vent-O-Mat was originally famous for were not compromised but further ones were incorporated into the new design.
- **"ANTI - SHOCK" - "ANTI - SURGE"** - The RGXII is an air release valve that is supplied as standard with a mechanism to prevent pipeline damage from the high induced pressure transients associated with high velocity air discharge. Surge resulting from liquid column separation and liquid oscillation is dramatically reduced as an automatic function of this mechanism. This same mechanism allows for controlled filling of the pipeline, maintaining controlled discharge at all times.
- **COMPACTNESS** - The RGXII is more compact and shorter without compromising the pressure rating of the valve.
- **FULL PORT OPENING ON NEGATIVE PRESSURE** - During pipeline draining and instances of surge, the valve will allow the intake of air to the full nominal bore of the valve. The RGXII series large orifice diameter equals the nominal size of the valve, i.e., a 8" valve has a 8" orifice. This ensures the least possible resistance to the intake of air and consequently the least possible negative pressure within a draining pipeline.
- **SEALING** - The RGXII has been designed for low head sealing as well where line pressures are generally lower than normal.
- **MATERIALS** - The RGXII is now available with a fusion bonded Ductile Iron Body as well as a 304 or 316 Stainless Steel Body.
- **PERFORMANCE** - The RGXII has been designed and developed to provide the optimum usable and safe performance relative to all functions.
- **QUALITY** - The RGXII economically offers the highest quality construction and materials available in an air release and vacuum break valve. Stringent manufacturing and test procedures are maintained to ensure the best possible service and reliability is given by every valve produced.
- **SERVICEABILITY** - The RGXII design facilitates extreme ease of service and maintenance. Components are in corrosion free materials to allow problem free disassembly and reassembly even after many years of operation. All maintenance spares are replaceable without special tools or skills.
- **BACK UP** - Vent-O-Mat provides highly committed customer orientated sales, service, spares and technical back up.



DJ Gongol & Associates, Inc.

PO Box 180 | West Des Moines, IA 50061-0180
4328 North Dawson | Cumming, IA 50061
515-223-4144 | 515-981-0581 fax
info@gongol.net

Series RGXII

RECOMMENDED INSTALLATION ARRANGEMENTS

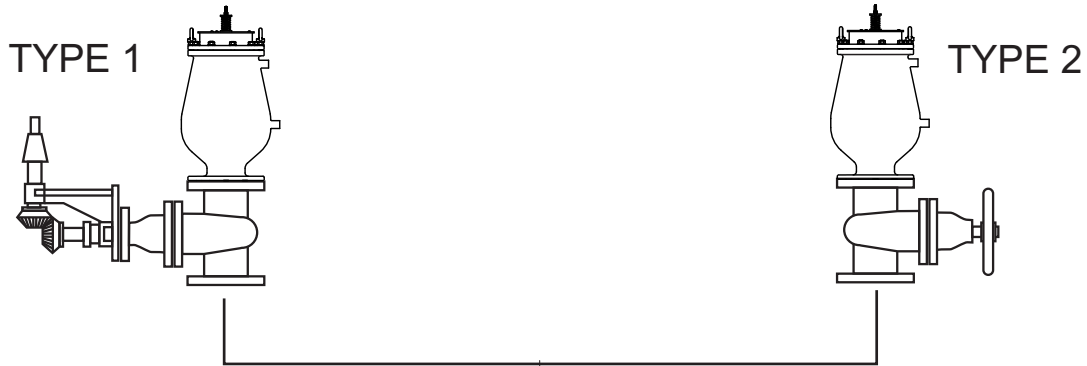

THE DEGREE OF TOLERANCE ALLOWED FOR THE EFFECTIVE OPERATION OF A VENT-O-MAT AIR RELEASE AND VACUUM BREAK VALVE IS **3 DEGREES FROM VERTICAL**

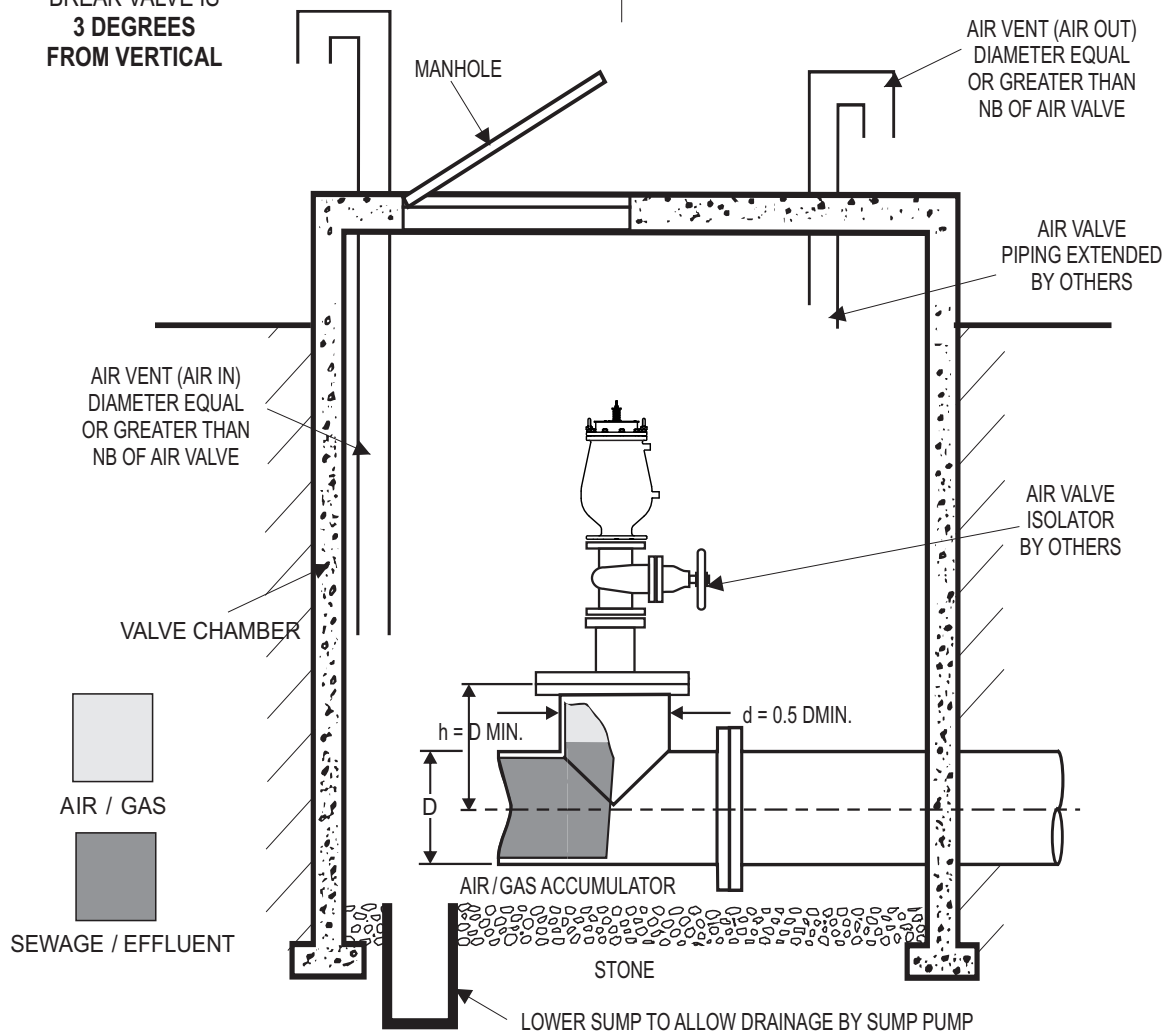

TYPICAL VALVE CHAMBER

Series RGXII OPERATION

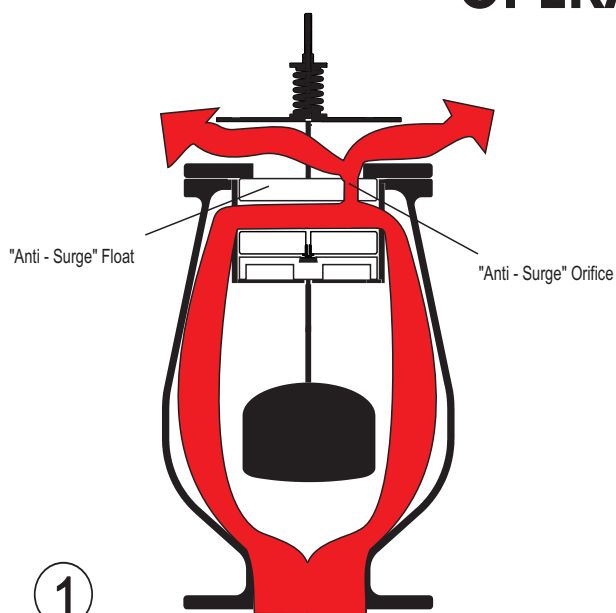

1

PIPELINE FILLING
(SUB CRITICAL AND EXCESSIVE
SEWAGE/ EFFLUENT APPROACH VELOCITY)

Air/gas flows through the annular area around the control float assembly and to atmosphere through the anti-surge float and out the large orifice.

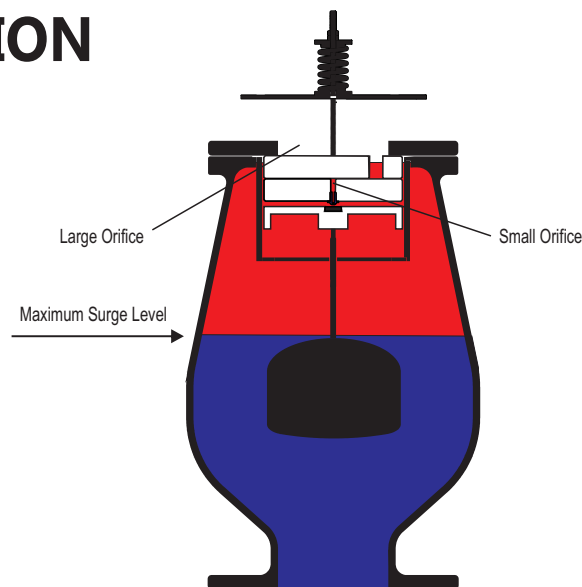

2

PIPELINE FULLY CHARGED

Sewage/effluent has entered the valve chamber and buoyed the floats to close both the large and the small orifice. The design's compression/ volume relationship prevents the media from ever exceeding the maximum surge level indicated above. The resultant sewage/ effluent free area protects against the fouling of the orifice seals by solids or high viscous substances

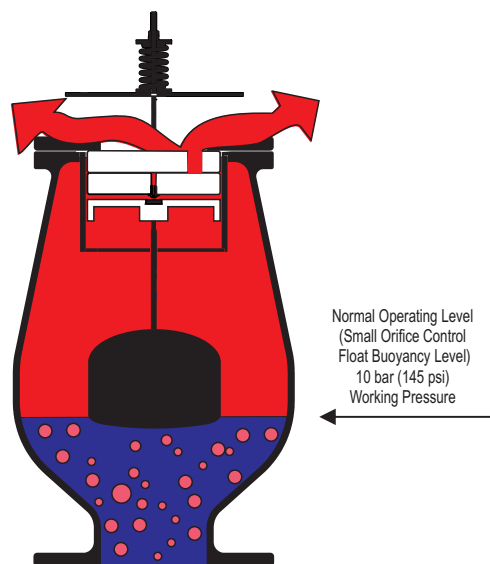

3

PRESSURIZED AIR/GAS RELEASE
PIPELINE OPERATING

The volume of disentrained air/gas increases in the valve, displacing the sewage/effluent to below the normal operating level. This results in the control float dropping away from the small orifice. The pressurized air/gas is then discharged to atmosphere. Once all additional air is discharged the control float will close the small orifice and restore the sewage effluent to the normal operating level.

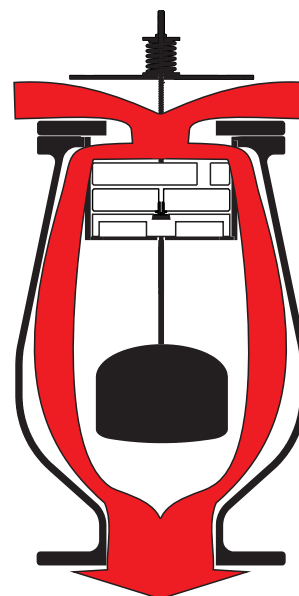

4

VACUUM RELIEF (AIR INTAKE)
PIPELINE DRAINING

Upon pump stop, Sewage/effluent drains from the sewage air valve and the negative differential created by the draining liquid causes atmospheric air to push the "Anti-Surge" Float down, opening the Large Orifice and allows air to displace the draining liquid to prevent potentially damaging internal negative pressure.

AVAILABLE DISCHARGE CONNECTIONS

2" TO 8"

Standard Screen Discharge
50 mm (2") to 200mm (8")



DJ Gongol & Associates, Inc.

PO Box 180 | West Des Moines, IA 50061-0180
4328 North Dawson | Cumming, IA 50061
515-223-4144 | 515-981-0581 fax
info@gongol.net

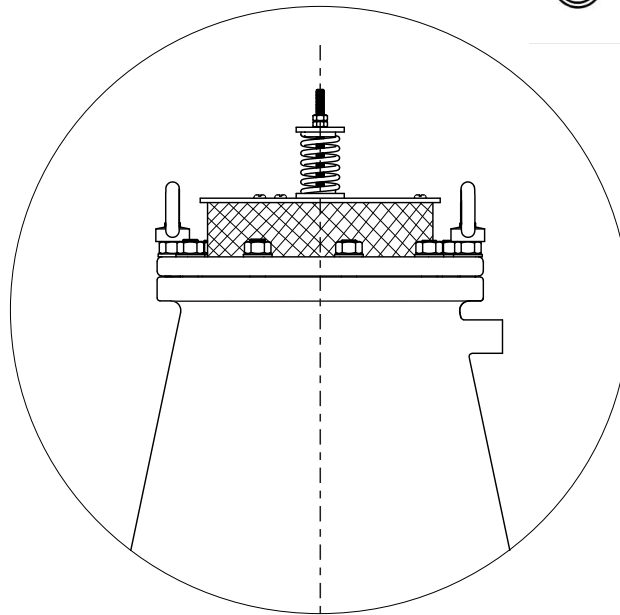

Alternative Arrangements can be provided on request

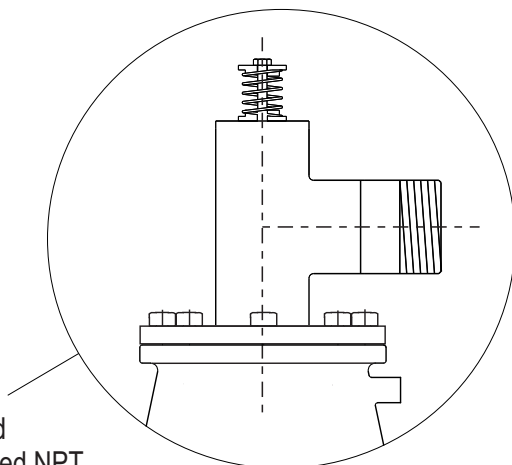

Biased
Screwed NPT
Discharge
50mm(2"), 80mm (3") &
100mm (4") Valves only.

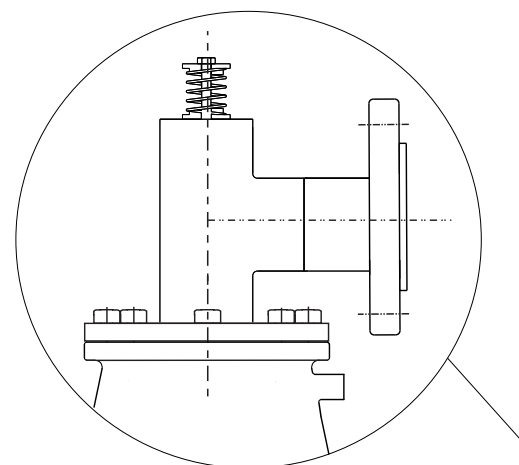

Biased
Swivel Discharge
50 mm (2") to 200mm (8")

***NOTE**
Discharge Connections Are Equal To Valve Pressure Rating

Information subject to change without prior notice

COMPONENT DESCRIPTION & MATERIAL SPECIFICATION EPOXY COATED CAST BODY - FLANGED INLET 2" - 8"

Type:
Series RGX II - Double Orifice (Small & Large Orifice)
with Anti Surge Orifice Mechanism.

End Connection:
Flat-faced flanged (ASME B16.5)

Nominal Sizes:

- DN50 - 2"
- DN80 - 3"
- DN100 - 4"
- DN150 - 6"
- DN200 - 8"

Model No's:

- RGXII 1041 E4 ANSI 150# 145 PSI
- RGXII 1641 E4 ANSI 150# 232 PSI

Pressure Ratings:

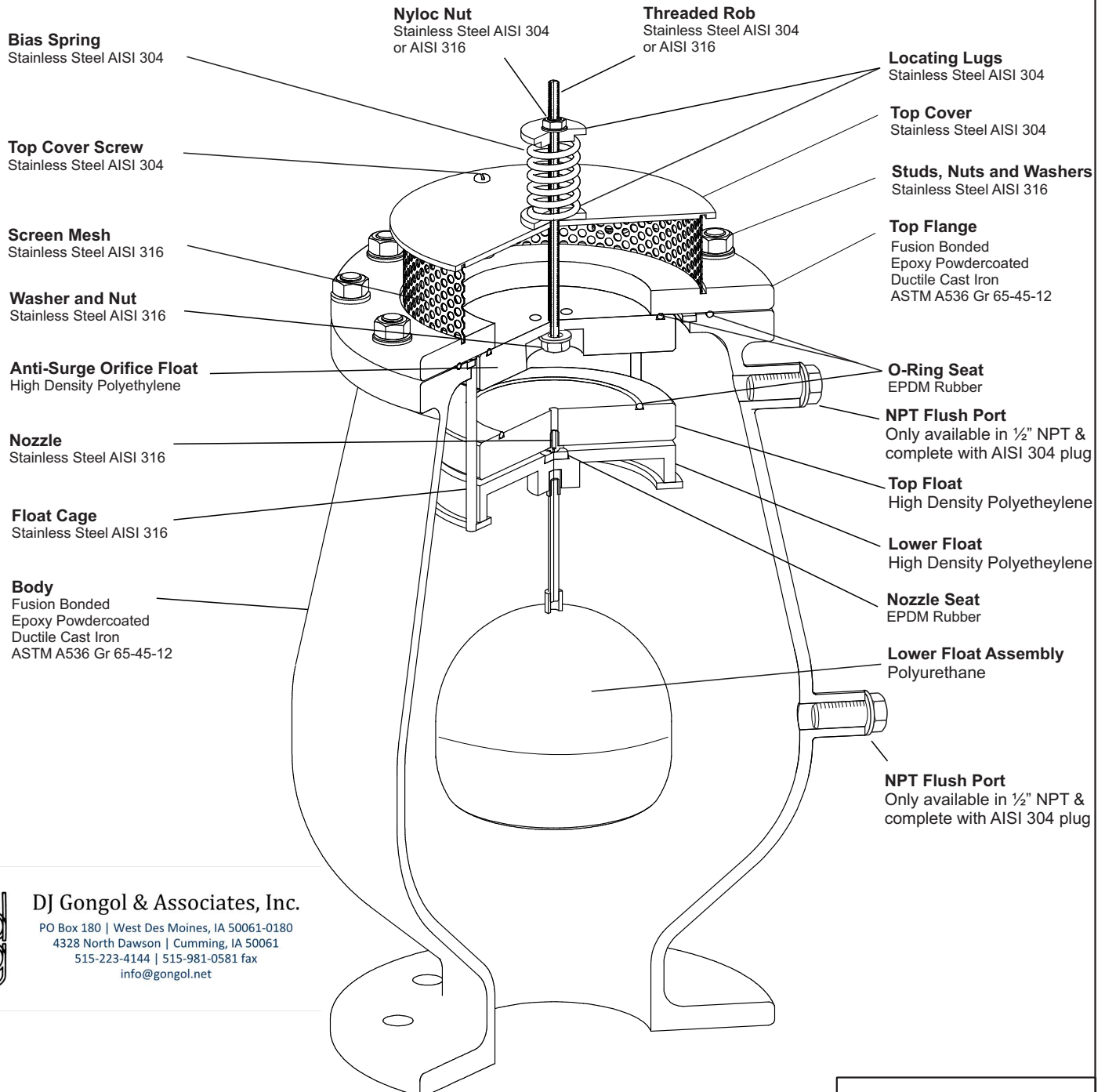

DJ Gongol & Associates, Inc.

PO Box 180 | West Des Moines, IA 50061-0180
4328 North Dawson | Cumming, IA 50061
515-223-4144 | 515-981-0581 fax
info@gongol.net

GENERAL SPECIFICATIONS
EPOXY COATED CAST BODY - FLANGED INLET 2" - 8"

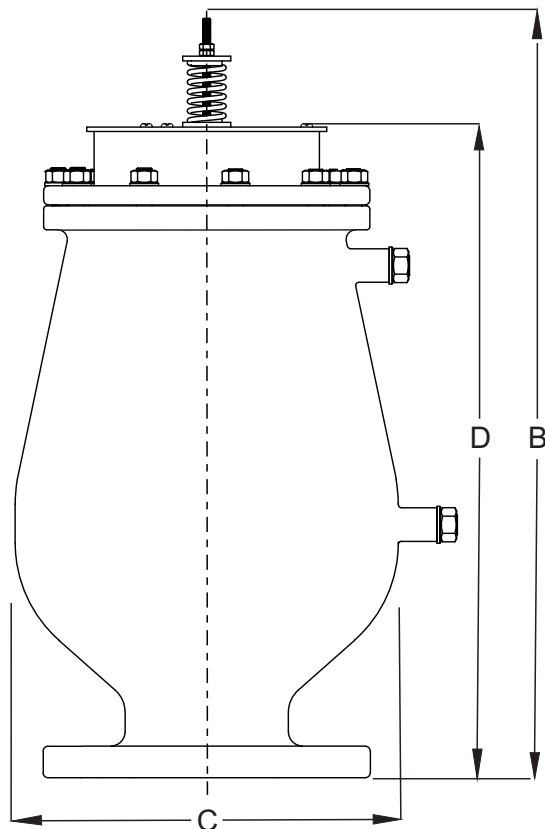
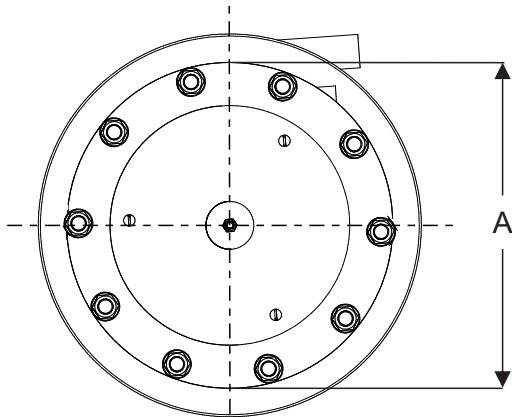

Type:

Double Orifice (Small & Large Orifice) with Bias mechanism for large volume air intake and controlled air discharge.

End Connection:

Flanged - ASME B16.5 Class 150

Nominal Sizes:

DN50 (2"), DN80 (3"), DN100 (4"), DN150 (6") & DN200 (8")

Operating Temperature Range:

40° to 176°F

Model No's:

RGXII 1041 E4

RGXII 1641 E4

Operating Pressure Range

2.9 psi to 145 psi

2.9 psi to 232 psi

Function:

- i) High volume air intake - pipeline draining
- ii) Pressurized air/gas discharge - pipeline filled.
- iii) Controlled air discharge - pipeline filling.
- iv) Surge dampening - high velocity air/gas discharge, liquid column separation & liquid oscillation.

Valve Selection:- Pages 10 - 11

Materials of Construction:- Page 5

Installation:- Page 2

Standard Factory Tests:

- i) Hydrostatic test -1.5 x max. rated working pressure
- ii) Low head leak test - 0.2 bar (2.9 psi)
- iii) Small orifice function test at max. rated working pressure (minimum 1 valve in 10).

OVERALL DIMENSIONS & WEIGHTS

DN		Model No.	A		B		C		D		Weight Cast	
mm	in		mm	in	mm	in	mm	in	mm	in	kg	lbs
50	2	050 RGXII 1641	174	6.85	413	16.26	155	6.10	363	14.29	16	35.27
80	3	080 RGXII 1641	230	9.06	640	25.20	273	10.75	546	21.50	40	88.18
100	4	100 RGXII 1641	230	9.06	645	25.39	273	10.75	546	21.50	40	88.18
150	6	150 RGXII 1041	340	13.39	772	30.39	400	15.75	680	26.77	70	154.32
200	8	200 RGXII 1041	355	13.98	940	37.01	526	20.71	846	33.31	115	253.53

COMPONENT DESCRIPTION & MATERIAL SPECIFICATION FULL STAINLESS STEEL BODY THREADED INLET 2" & FLANGED INLET 2" - 8"

Type:
Series RGX II - Double Orifice (Small & Large Orifice)
with Anti Surge Orifice Mechanism.

End Connection:
Screwed NPT (ASME B1.20.1) 2" only
Flat-Faced Flanged (ASME B16.5) 2" to 8"

Nominal Sizes:

- DN50 - 2"
- DN80 - 3"
- Dn100 - 4"
- DN150 - 6"
- DN200 - 8"

Model No's:

RGXII 1041 S4	___ ANSI 150# ___	145 PSI
RGXII 1621 S4	___ NPT ___	232 PSI
RGXII 1641 S4	___ ANSI 150# ___	232 PSI

Pressure Ratings:

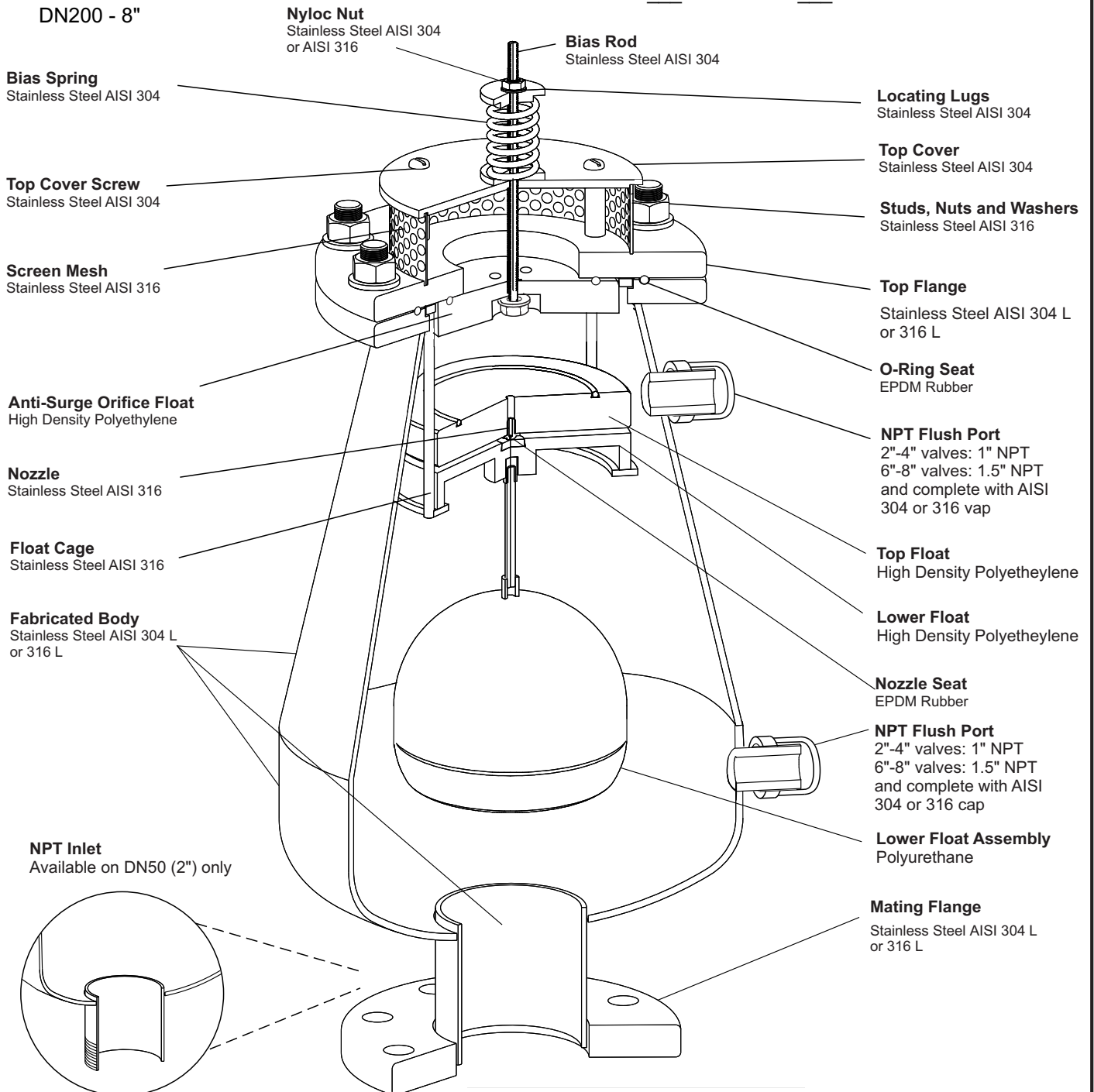

Information subject to change without prior notice



DJ Gongol & Associates, Inc.

PO Box 180 | West Des Moines, IA 50061-0180
4328 North Dawson | Cumming, IA 50061
515-223-4144 | 515-981-0581 fax
info@gongol.net

page: 7
Revision Date: Aug '15

GENERAL SPECIFICATIONS FULL STAINLESS STEEL BODY THREADED INLET 2" & FLANGED INLET 2" - 8"

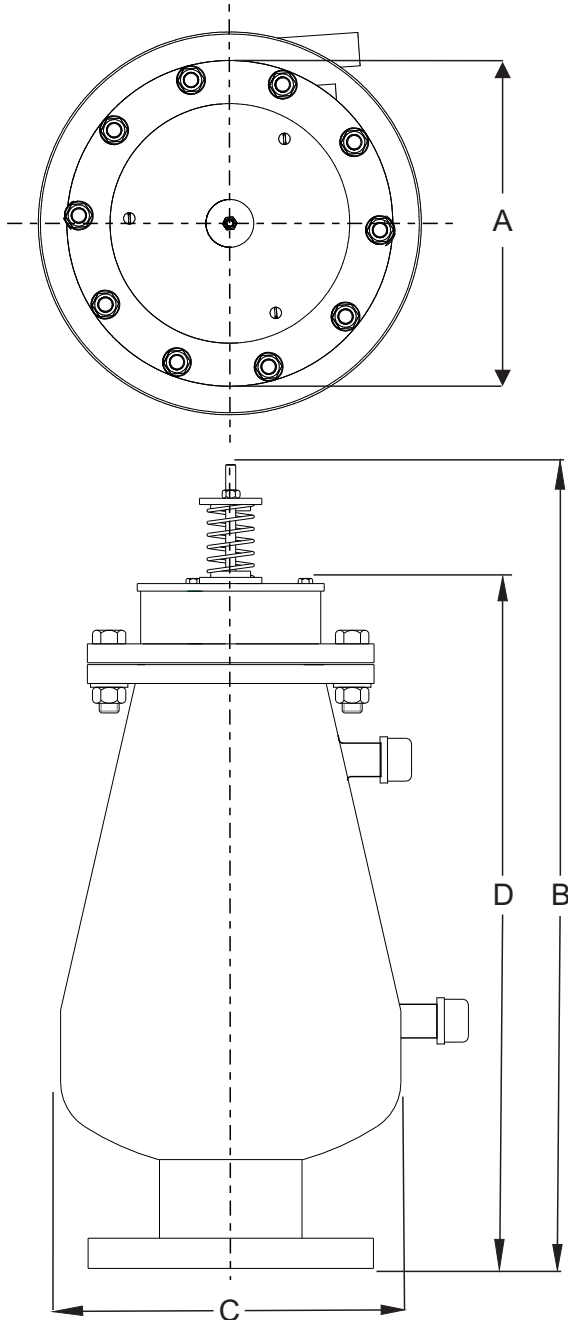

Type:

Double Orifice (Small & Large Orifice) with Bias mechanism for large volume air intake and controlled air discharge.

End Connection:

Screwed NPT (ASME B1.20.1) 2" only
Flanged - (ASME B16.5 Class 150) 2" - 8"

Nominal Sizes:

DN50 (2"), DN80 (3"), DN100 (4"), DN150 (6") & DN200 (8")

Operating Temperature Range:

40° to 176°F

Model No's:

RGX II 1041 S4 _____
RGX II 1621 S4 _____
RGX II 1641 S4 _____

Operating Pressure Range

2.9 psi to 145 psi
2.9 psi to 232 psi
2.9 psi to 232 psi

Function:

- i) High volume air intake - pipeline draining
- ii) Pressurized air/gas discharge - pipeline filled.
- iii) Controlled air discharge - pipeline filling.
- iv) Surge dampening - high velocity air/gas discharge, liquid column separation & liquid oscillation.

Valve Selection:- Page 10 - 11

Materials of Construction:- Page 7

Installation:- Page 2

Standard Factory Tests:

- i) Hydrostatic test -1.5 x max. rated working pressure
- ii) Low head leak test - 0.2 bar (2.9 psi)
- iii) Small orifice function test at max. rated working pressure (minimum 1 valve in 10).

*** 2" NPT SCREWED INLET VALVE AVAILABLE ON REQUEST**

OVERALL DIMENSIONS & WEIGHTS

DN		Model No.	A		B		C		D		Weight S/Steel	
mm	in		mm	in	mm	in	mm	in	mm	in	kg	lbs
50	2	050 RGXII 1641	174	6.85	410	16.16	141	5.55	360	14.21	13	28.66
80	3	080 RGXII 1641	230	9.06	650	25.60	273	10.75	550	21.65	30	66.14
100	4	100 RGXII 1641	230	9.06	650	25.60	273	10.75	550	21.65	30	66.14
150	6	150 RGXII 1041	340	13.39	798	31.45	406	16.00	704	27.70	60	132.28
200	8	200 RGXII 1041	355	13.98	950	37.41	508	20.00	856	33.70	80	176.37

SMALL ORIFICE DISCHARGE PERFORMANCE

Type:
Series RGXII - Double Orifice (Small & Large Orifice)
with "Anti-Surge" Orifice Mechanism

Model No's:
RGXII 1041
RGXII 1621
RGXII 1641

- █ " 2mm (0.07") small orifice - DN50 (2"), DN80 (3"), DN100 (4") Valves
- █ " 5mm (0.20") small orifice - DN150 (6") Valves
- █ " 6mm (0.24") small orifice - DN200 (8") Valves

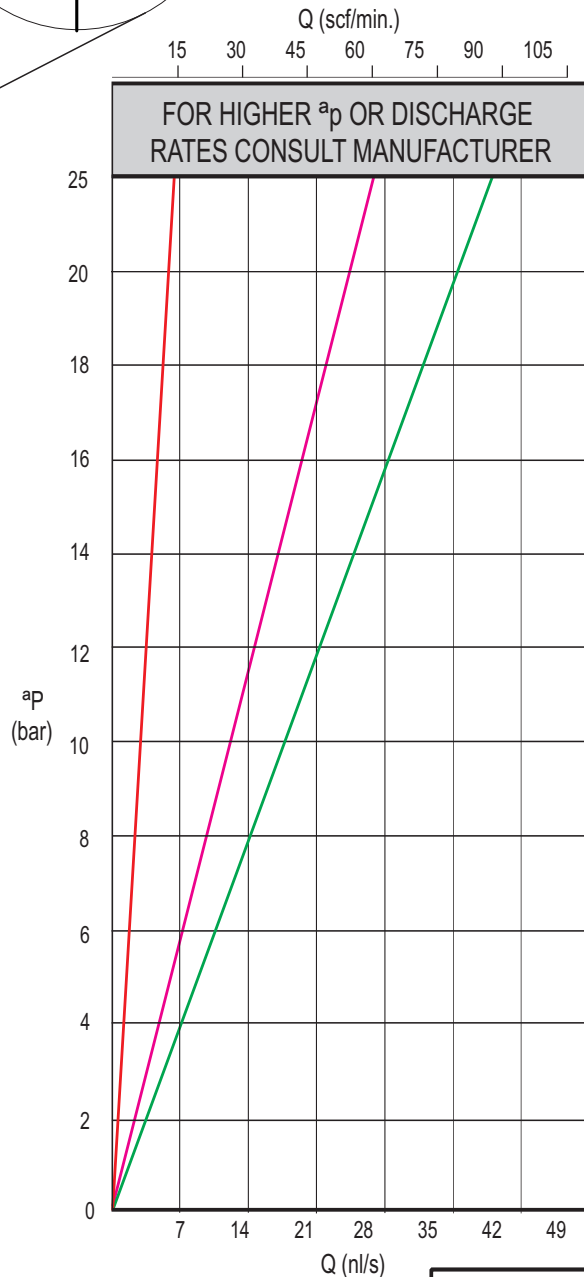
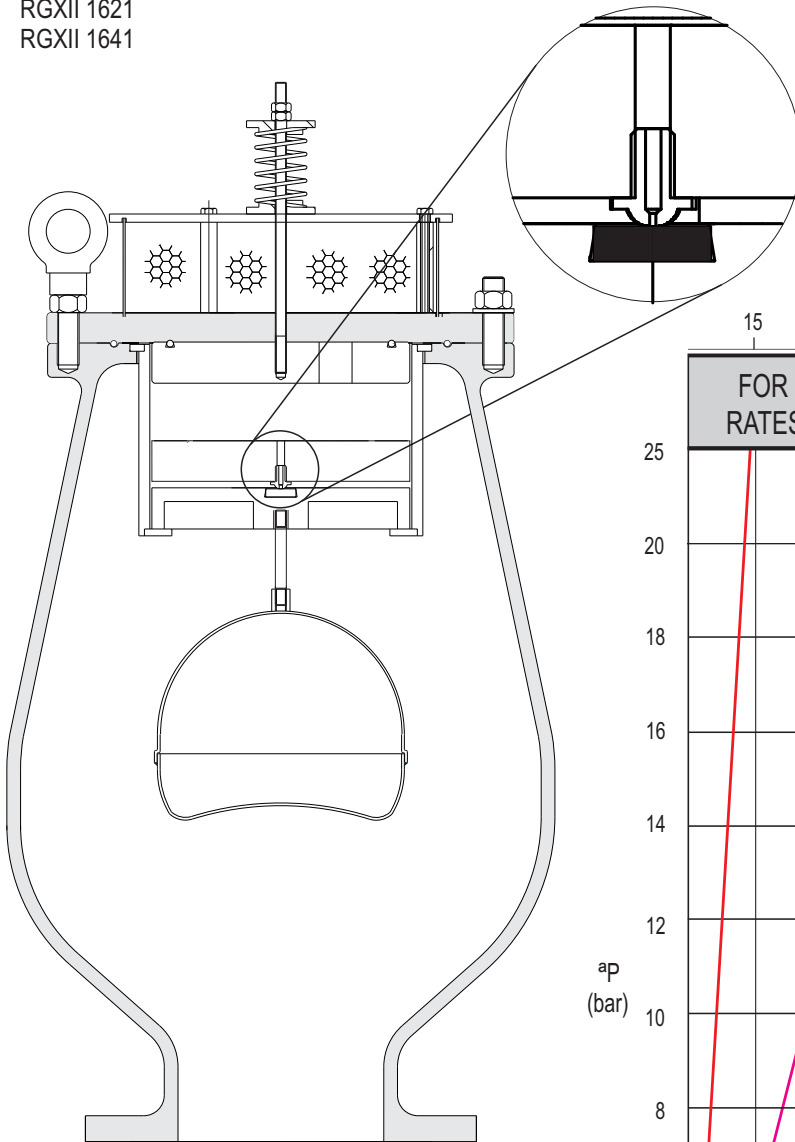

Q = Normal Litres per second (Free Air) @ 1.01325 bar Abs. and 20 deg. C	Q = Standard Cubic Feet per minute (Free Air) @ 14.7 psi Abs. 68 deg. F
CONVERSION EQUIVALENTS	
1 l/ sec. = 2.1189 scf/ min.	1 scf/ min = 0.472 l/ sec.
1 bar = 14.5 psi	1 psi = 0.069 bar

SELECTION & POSITIONING

VALVE SELECTION FROM GRAPH

All the relevant information has been condensed into one graph to enable valve selection to be simple and easy and at the same time to allow flexibility to the designer to move within certain parameters which eventually allows the most suited and economically viable valve to be selected.

IMPORTANT NOTE: The graph is based on vacuum breaking and limiting vacuum to 0.34 bar (5 psi) below atmospheric. It is not good practice to go below 0.69 bar (10 psi) absolute (0.303bar (4.4 psi) differential in pipeline at sea level). The graph allows for change in altitude and hence change in atmospheric pressure and is based on the assumption that more than one valve per section is used for vacuum protection and venting

ACTUAL SELECTION (GRAVITY OR PUMPED PIPELINES)

Selection is based on the premise that pipelines are generally filled at a slower rate than they are drained, scoured or at which separation occurs (a maximum fill/ drain ratio of 1:1).

1. Determine the maximum drainage rate in m/s either for scouring, pipe rupture or column separation for a particular pipeline section.
2. Move vertically on the graph from the m/s point and move horizontally from the pipe size finding the intersecting point.
3. This point should fall within the operating band of a particular valve size. Consideration must be given to the fact that the upper portion of the band approaches - 0.34 bar (5 psi) and the lower portion - 0.1 bar (1.45 psi) for each valve size, this allows the designer to see at a glance if the valve is too close to it's operating limits and to select the next valve size.

EXAMPLE OF VALVE SIZING (ASSUMING AN INDIVIDUAL SECTION)

A \varnothing 400mm (16") pipeline draining at 377l/sec which equates to 3m/sec (10ft/s) what valve size should be selected?

From the 3m/sec (10ft/s) point, move vertically until the \varnothing 400mm (16") pipe size horizontal line is intersected. This places the intersection point squarely in the centre of the operating band of a DN80 (3") Vent -O- Mat RGXII valve. But, if for example, the drainage rate is 503l/sec which equates to 4m/sec (13.2ft/s), the valve would be operating on it's limit and it may be prudent to change to a DN100 (4") Vent-O-Mat RGXII.

VALVE POSITIONING

1. ON APEX POINTS (relative to hydraulic gradient).
2. 5 METERS (16 FEET) BELOW APEX POINTS FORMED BY INTERSECTION OF PIPELINE AND HYDRAULIC GRADIENT - i.e. where pipeline siphoning over Gradient a sewage air release valve positioned on the apex would break the siphon. If positioning on apex is required a modified VENT -O- MAT Series RGX may be supplied.
3. NEGATIVE BREAKS (increase in downward slope or decrease in upward slope).
4. LONG HORIZONTAL SECTIONS - every 600 meters (1/3 of a mile) maximum.
5. LONG ASCENDING SECTIONS - every 600 meters (1/3 of a mile) maximum.
6. LONG DESCENDING SECTIONS - every 600 meters (1/3 of a mile) maximum.
7. PUMP DISCHARGE (not shown in diagram) - just subsequent to non return valve.
8. BLANK ENDS (not shown in diagram) - where a pipeline is terminated by a blind flange or a valve.

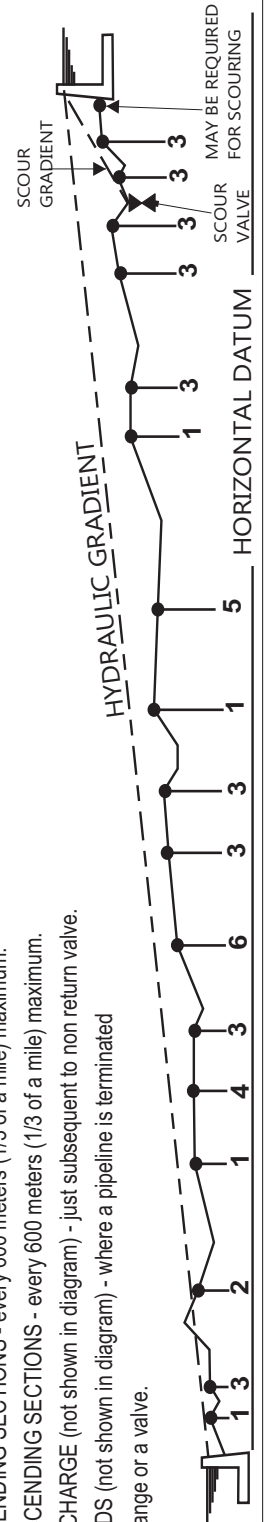

SELECTION & POSITIONING

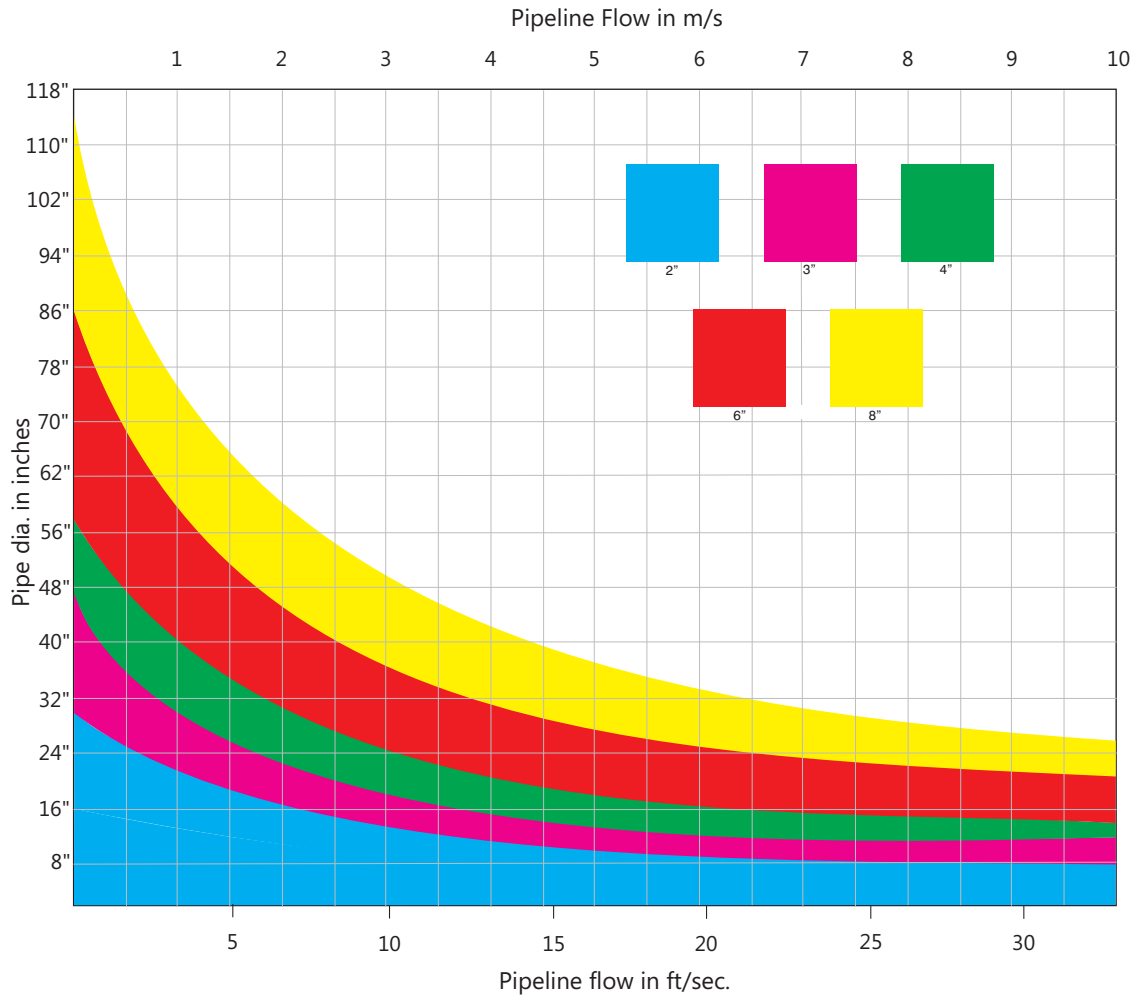

Pipe Dia Inches	2	3	5	7	8	10	11	13	15	16	18	20	21	23	25	26	28	30	31	33
4	78	117	196	274	313	391	431	509	587	626	705	783	822	900	979	1018	1096	1174	1214	1292
6	176	264	440	617	705	881	969	1145	1321	1409	1585	1762	1850	2026	2202	2290	2466	2642	2731	2907
8	313	470	783	1096	1253	1566	1722	2036	2349	2505	2819	3132	3288	3602	3915	4071	4385	4698	4854	5167
10	489	734	1223	1713	1957	2447	2691	3181	3670	3915	4404	4893	5138	5627	6117	6361	6851	7340	7585	8074
12	705	1057	1762	2466	2819	3523	3876	4580	5285	5637	6342	7047	7399	8104	8808	9161	9865	10570	10922	11627
14	959	1439	2398	3357	3836	4796	5275	6234	7193	7673	8632	9591	10071	11030	11989	12469	13428	14387	14866	15825
16	1253	1879	3132	4385	5011	6264	6890	8143	9395	10022	11275	12527	13154	14406	15659	16285	17538	18791	19417	20670
18	1585	2378	3964	5549	6342	7927	8720	10306	11891	12684	14269	15855	16648	18233	19818	20611	22197	23782	24575	26160
20	1957	2936	4893	6851	7830	9787	10766	12723	14680	15659	17616	19574	20552	22510	24467	25446	27403	29361	30339	32297
22	2368	3553	5921	8289	9474	11842	13026	15395	17763	18947	21316	23684	24868	27237	29605	30790	33158	35526	36711	39079
24	2819	4228	7047	9865	11275	14093	15502	18321	21140	22549	25368	28186	29596	32414	35233	36642	39461	42279	43689	46507
26	3308	4962	8270	11578	13232	16540	18194	21502	24810	26464	29772	33080	34734	38042	41350	43004	46312	49620	51274	54582
28	3836	5755	9591	13428	15346	19182	21101	24937	28773	30692	34528	38365	40283	44119	47956	49874	53710	57547	59465	63302
30	4404	6606	11010	15414	17616	22021	24223	28627	33031	35233	39637	44041	46243	50647	55051	57253	61657	66062	68264	72668
32	5011	7516	12527	17538	20044	25054	27560	32571	37582	40087	45098	50109	52614	57625	62636	65142	70152	75163	77669	82680
34	5657	8485	14142	19799	22627	28284	31113	36769	42426	45255	50911	56568	59397	65053	70710	73539	79196	84852	87681	93338
36	6342	9513	15855	22197	25368	31710	34880	41222	47564	50735	57077	63419	66590	72932	79274	82445	88787	95129	98300	104641
38	7066	10599	17665	24731	28265	35331	38864	45930	52996	56529	63595	70661	74194	81261	88327	91860	98926	105992	109525	116591
40	7830	11744	19574	27403	31318	39148	43062	50892	58721	62636	70466	78295	82210	90039	97869	101784	109613	117443	121357	129187
44	9474	14211	23684	33158	37895	47369	52105	61579	71053	75790	85263	94737	99474	108948	118421	123158	132632	142106	146843	156316
48	11275	16912	28186	39461	45098	56373	62010	73284	84559	90196	101471	112745	118382	129657	140931	146569	157843	169118	174755	186029
52	13232	19848	33080	46312	52928	66159	72775	86007	99239	105855	119087	132319	138935	152167	165398	172014	185246	198478	205094	218326
56	15346	23019	38365	53710	61383	76729	84402	99748	115094	122767	138113	153458	161131	176477	191823	199496	214842	230188	237861	253206
60	17616	26425	44041	61657	70466	88082	96890	114507	132123	140931	158548	176164	184972	202589	220205	229013	246630	264246	273054	290671
62	18810	28216	47028	65836	75242	94052	103457	122268	141078	150483	169294	188104	197509	216320	235130	244535	263346	282156	291561	310372
66	21316	31974	53290	74605	85263	106579	117237	138553	159869	170527	191843	213159	223816	245132	266448	277106	298422	319738	330396	351712
70	23979	35967	59445	83323	95912	119898	131878	155864	179834	191823	215809	239795	251781	275766	299752	311737	335722	359707	371692	395678
74	26780	40195	66591	93788	107186	133983	147381	174177	200974	214372	241169	267966	281363	308160	334956	348353	375151	401948	415346	442142
78	29772	44658	74429	104201	119087	148859	163745	193516	223288	238174	267946	297717	312603	342375	372147	387032	416804	446576	461462	491234
82	32904	49355	82558	115162	131614	164518	180969	213873	246777	263228	296132	329036	345487	378391	411294	427746	460649	493552	510005	542908
86	36192	54288	90480	126672	144768	180960	199056	235248	271439	289535	325727	361919	380015	416207	452399	470495	506687	542879	560975	597167
90	39637	59455	99092	138729	158548	198185	218003	257640	297277	317095	356732	396369	416188	455825	495461	515280	554917	594554	614372	654009
94	43238	64858	108096	151335	172954	216192	237812	281050	324289	345908	391448	432385	454004	497243	540481	562100	605339	648577	670197	713435
98	46997	70495	117492	164488	187987	234983	258482	305478	352475	375073	422070	469067	493465	540462	587458	610957	657953	704950	728448	775445
102	50911	76367	127279	178190	203646	254557	280013	330924	381835	407291	458203	509114	534570	585481	636393	661848	712760	763671	789127	840038
106	54983	82474	137457	192440	219931	274914	302405	357388	412371	439862	494845	549828	577319	632302	687285	714776	769759	824742	852233	907216
110	59211	88816	148027	207237	236843	296054	325659	384870	444080	473686	52896	592107	621712	680923	740134	769739	828950	888161	917766	976977
114	63595	95393	158988	222583	254381	319776	349774	413369	476964	506762	572357	635952	667750	731345	794940	826738	890333	953928	985726	1049321
118	68136	102205	170341	238477	272545	340682	374750	442886	511023	545091	613227	681363	715432	783568	851704	885773	953909	1022045	1056113	1124250

Conversion Table ft/sec of Pipeline Velocity to gal/min

Series RGXII

SURGE & WATERHAMMER PROTECTION

Introduction

The Vent-O-Mat Series RGXII "Anti-Surge" sewage air release and vacuum break valve, is an evolution of market feedback and the incorporation of the already proven Vent-O-Mat technology which itself resulted from years of extensive research. The valve unlike many others is not just an adaption of an air valve to handle sewage, but the result of over 30 years of dealing with sewage and seeing what works and adapting it to the needs of the end user.

Surge Protection - Initial Filling

The RGXII is always biased in the "Anti-Surge" mode meaning all air release is controlled through the "Anti-Surge" Orifice which is aerodynamically engineered to throttle air discharge when liquid approach velocity would otherwise become too great and induce an unacceptable pressure rise. The air throttling action increases resistance to the flow of the approaching liquid which consequently decelerates to a velocity which reduces the pressure rise when the valve closes (see operation of valve on page 3). Vent-O-Mat series RGXII is an essential precaution for pipeline priming.

Surge Protection - Pump Trip Conditions

In instances where a pipeline experiences liquid column separation due to pump stoppage, high shock pressures can be generated when the separated liquid column rejoins.

The Vent-O-Mat series RGXII takes in air through the unobstructed large orifice when liquid column separation occurs, but controls the discharge of air/gas through the "Anti-Surge" Orifice as the separated column commences to rejoin. The rejoining impact velocity is thereby considerably reduced to alleviate high surge pressures in the system (see operation of valve on page 3).

Other surge control measures may, dependant on pipeline profile, diameter and operating conditions, be needed to provide the primary surge alleviation function with the Vent-O-Mat sewage air-valves forming an integral and valuable addition in a combined strategy for further reducing surge pressures. The benefit of the "Anti-Surge" Orifice can be readily demonstrated by suitable surge modelling software.

Surge Protection - Pipeline Operating

The operation of valves and similar flow control devices can cause high-pressure transients in an operating pipeline.

The unique, single chamber design of the Vent-O-Mat series RGXII valve enables a pocket of air to be trapped in the valve chamber. Automatic operation of the small orifice control float regulates the volume of air entrapped.

The volume maintained in the valve will provide a cushioning benefit to the pipeline for short duration transient pressure "spikes". This effect can be modelled by the design engineer using suitable surge software.

Computer Modelling

The effectiveness of Vent-O-Mat "Anti-Surge" technology has been substantiated by independent third party testing and by thousands of applications globally. Effective computer modelling, based on practical tests, has been ensured in the well-known and respected commercially available surge analysis software programmes such as AFT impulse, FLOWMASTER, WATHAM and SURGE 2000.

Technical and Financial Benefits

1. Improved alleviation of surge behaviour including reduction of:
 - Surge pressure magnitudes by slowing surge velocities
 - Duration of oscillation following a pump trip, as the sewage air-valve continuously absorbs and dissipates the energies of the surge.
2. Potential for reduction in size and/or quantity of conventional surge protection devices such as surge vessels etc.
3. Automatic protection during initial filling when most surge protection devices are not operational.
4. Holistic protection as each sewage air valve installed has design features to automatically damp surges.
5. The valve is virtually maintenance free.

PURCHASE SPECIFICATION

VENT -O- MAT MODEL NO.

Page 6 - Series RGX II (epoxy coated cast body)

Page 8 - Series RGX II (full stainless steel)

CONSTRUCTION & DESIGN

The Sewage Air Release & Vacuum Break Valve shall consist of a single chamber ductile iron or stainless steel body, stainless steel direct acting float, solid small orifice top float and "Anti-Surge" float in H.D.P.E. - A stainless steel nozzle, stainless steel top cap and E.P.D.M. rubber seals and seat.

The valve shall have an integral "Anti-Surge" Orifice mechanism which shall limit transient pressure rise or shock induced by closure to less than 1.5 x valve rated working pressure, however, must open to the full diameter of the valve size during a negative pressure.

The intake orifice area shall be equal to the nominal size of the valve i.e., a 150mm (6") valve shall have a 150mm (6") intake orifice. Large orifice sealing shall be effected by the flat face of the anti-surge control float seating against a E.P.D.M. rubber 'O' ring housed in a dovetail groove circumferentially surrounding the orifice.

Discharge of pressurized air shall be controlled by the seating & unseating of a small orifice nozzle on a E.P.D.M. rubber seal affixed into the float. The nozzle shall have a flat seating land surrounding the orifice so that damage to the rubber seal is prevented.

The valve construction shall be proportioned with regard to material strength characteristics, so that deformation, leaking or damage of any kind does not occur by submission to 1.5 times the designed working pressure. Connection to the valve inlet shall be facilitated by flanged ends conforming to ANSI B16.5 Class 150 and Screwed NPT. Flanged ends shall be supplied drilled to the Specified Standard.

OPERATION

1. Prior to the ingress of liquid into the valve chamber, as when the pipeline is being filled, valves shall vent through the "Anti-Surge" orifice at all times.
2. Valves shall be tested and not exhibit leaks or weeping of liquid past the large orifice seal at operating pressures of 0.2 bar (2.9 psi) to 1.5 x valve rated working pressure.
3. When the pipeline is fully charged valves shall respond to the presence of air/gas by discharging it through the small orifice at the pressures within the specified design range, and shall remain leak tight in the absence of air.
4. Valves shall react immediately to pipeline drainage or liquid column separation by the full opening of the large orifice so as to allow unobstructed air intake at the lowest possible negative internal pipeline pressure.



DJ Gongol & Associates, Inc.

PO Box 180 | West Des Moines, IA 50061-0180
4328 North Dawson | Cumming, IA 50061
515-223-4144 | 515-981-0581 fax
info@gongol.net

ORDERING GUIDE

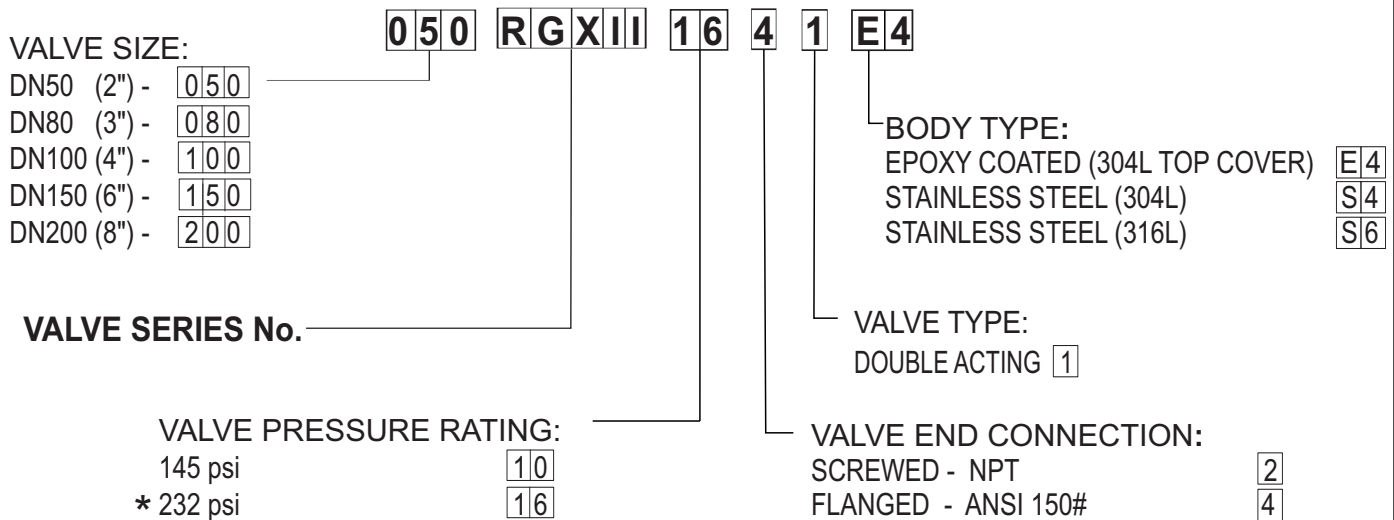

Note:

1. Valves are available with threaded or flanged outlets, please specify when ordering.
2. * 16Bar (232psi) only available for 2" - 4"

TEST SPECIFICATIONS

All air release valves supplied shall be subjected to the following testing procedures in the order laid down:
 (A) A high pressure strength and leak test whereby the valve is filled with water and pressurized to twice the rated working pressure which shall be held for a period of 2 minutes. Any leaking, weeping or sweating shall be reason for rejection.

(B) A low head leak test whereby the valve is filled with water and pressurized to a maximum of 0.2 bar (2.9 psi) using a visible water column connected to the test rig. The valve shall be rejected if leak tightness is not maintained for 2 minutes.

(C) Every tenth air release valve of the same size and pressure rating must be subjected to a small orifice function test "DROP TEST" - whereby the valve is filled with water, pressurized to above rated working pressure and isolated from the test rig by closure of an isolating valve. A chamber in the test rig immediately prior to the isolating valve must be filled with compressed air at a pressure equal to that being maintained in the air release valve. The isolating valve is then opened so as to allow the air to rise in the air release valve without the pressure dropping lower than 2 - 3 bar (29 - 44 psi) above rated working pressure of the air release valve. The "DROP TEST" is then carried out by slowly bleeding off the pressure through a suitable cock until rated working pressure is reached and the float drops away from the orifice to allow discharge. Failure of the air release valve to function in the manner described will be reason for rejection.

On request the manufacturer shall provide batch certificates of test compliance which shall be cross referenced to serial numbers indelibly marked onto the identity label of each valve.

IMPORTANT NOTE: It is impossible to inject air into an incompressible liquid, air injection can only be achieved if the liquid can be displaced which implies that the pressure in the test rig must be reduced to atmospheric, and absolutely nothing is proven by discharge through the small orifice of the air release valve at atmospheric pressure. "DROP TESTING" in this manner is not acceptable.

Copy and Complete the Form Below For Any Additional Information and E-mail, Fax or Mail to:

RF Valves Inc.
 1342 Charwood Rd., Suite A
 Hanover, MD 21076 • USA
 Phone: +1-410-850-4404 • Fax: +1-410-850-4464

E-mail: rfq@rfvalve.com



DJ Gongol & Associates, Inc.
 PO Box 180 | West Des Moines, IA 50061-0180
 4328 North Dawson | Cumming, IA 50061
 515-223-4144 | 515-981-0581 fax
info@gongol.net

Or contact us via our Website
www.rfvalve.com

Company Name:

Postal Address:

Postal Code: **Country:**

Tel: **Fax:** **Email:**

Contact Name: **Title:**

Comments:

.....

Products you are interested in:**VENT-O-MAT® Series RBXc Air Release & Vacuum Break Valves**

Compact single chamber design with integral "Anti-Shock" surge dampening mechanism in an economical cast ductile iron construction

VENT-O-MAT® Series RBX Air Release & Vacuum Break Valves

Compact stainless steel single chamber design with integral "Anti-Shock" surge dampening mechanism

VENT-O-MAT® Series RGX Series Air Release & Vacuum Break Valves

Compact stainless steel or ductile iron single chamber design with integral "Anti-Shock" surge dampening mechanism for sewage applications

VENT-O-MAT® Series RPS Air Release & Vacuum Break Valves

Glass reinforced polypropylene CATT air valve for industrial, irrigation and small reticulation systems

VENT-O-MAT®

AIR RELEASE & VACUUM BREAK VALVES SERIES RGXII “ANTI - SURGE”

The Unique defence against pipe bursts and pipeline system damage!

The Vent-O-Mat Series RGXII "Anti-Surge" sewage air release and vacuum break valve, is an evolution of market feedback and the incorporation of the already proven Vent-O-Mat technology which itself resulted from years of extensive research. The valve unlike many others is not just an adaption of an air valve to handle sewage valve but the result of over 30 years of dealing with sewage and seeing what works and adapting it to the needs of the end user

The basis of the Vent-O-Mat design is in the understanding of the physical laws that govern air valve and pipeline operation. Reaction to pipeline dynamics is therefore instantaneous and protection provided is relevant to the pipeline's needs.

Vent-O-Mat Series RGXII truly represents the pinnacle of valve design evolution. This valve design provides the most comprehensive, effective and efficient pipeline protection relative to initial cost of any other available pipeline component. This can easily be gauged from the below:

Automatic Surge Protection

The unique Series RGXII valve incorporates as standard, three design features to automatically protect a pipeline, under all pipeline operating conditions, from the destructive surge and water hammer phenomena. These features are independent of any mechanical devices ensuring reaction in a very low millisecond time span.

Effective Air Release

The RGXII design ensures effective de-aeration under all pipeline flow and operating conditions, via either one of three discharge orifices.

Vacuum Protection

The RGXII series large orifice diameters equal the nominal size of the valve. This ensures the least possible resistance to the intake of air and consequently the least possible negative pressure within a draining pipeline. The use of solid, cylindrical floats ensures instantaneous reaction, discourages the "Venturi" phenomenon and is a further guarantee of effective vacuum protection.

Guaranteed Performance

The RGXII has been designed and developed to provide the optimum usable and safe performance relative to all functions. Selection data has been substantiated through third party testing and can therefore be confidently referenced.

The surge protection function of the RGXII design has been incorporated in the well-known SURGE 2000 surge analysis software program and can be analyzed with great accuracy in other commercially available surge analysis programs such as FLOWMASTER and TRANSAM.

Unparalleled Service

Vent-O-Mat is committed to customer service and to the selling of solutions. Our highly dedicated team is available at all times to assist with air valve sizing and positioning. Assistance is also provided in finding the most cost effective and/or efficient surge protection strategy relevant to the pipeline's needs.

International Representation

Vent-O-Mat is represented in the following countries and regions:

* USA	* Thailand	* South Africa	* Tanzania	* Kuwait
* Canada	* Germany	* Mexico	* Hong Kong	* Brazil
* Caribbean	* Peru	* Chile	* Taiwan	* France
* United Arab Emirates	* Egypt	* Malawi	* New Zealand	* Singapore
* South America	* UK	* Zambia	* Vietnam	* Australia

VENT-O-MAT®

RF Valves, Inc. (Hereinafter referred to as Seller)

STANDARD TERMS AND CONDITIONS

1. CONTROLLING PROVISIONS: These terms and conditions shall control with respect to any purchase order or sale of Seller's products. No waiver, alteration or modification of these terms and conditions whether on Buyer's purchase order or otherwise shall be valid unless waiver, alteration or modification is specifically accepted in writing and signed by an authorized representative of Seller.

2. DELIVERY: Seller will make every effort to complete delivery of products as indicated on Sellers acceptance of an order, but Seller assumes no responsibility or liability, and will accept no back charge for loss or damage due to delay or inability to deliver caused by acts of God, war, labor difficulties, accident, delays of carriers, by contractors or suppliers, inability to obtain materials, shortages of fuel and energy or any other causes of any kind whatever beyond the control of Seller. Seller may terminate any contract of sale of its products without liability of any nature, by written notice to Buyer, in the event that the delay in delivery or performance resulting from any of the aforesaid causes shall continue for a period of sixty (60) days. Under no circumstances shall Seller be liable for any special or consequential damages or for loss, damage or expense (whether or not based on negligence) directly or indirectly arising from delays or failure to give notice of delay.

3. WARRANTY: Seller warrants RF Pinch and RF-SKG for one year and Vent-O-Mat for limited 10 years from the date of shipment Seller's manufactured products to the extent that Seller will replace those having defects in material or workmanship when used for the purpose and in the manner which Seller recommends. Vent-O-Mat 10 year limited warranty applies to internal parts only. If Seller's examination shall disclose to its satisfaction that the products are defective, and an adjustment is required, the amount of such adjustment shall not exceed the net sales price of the defective products only and no allowance will be made for labor or expense of repairing or replacing defective products or workmanship or damage resulting from same. Seller does not guarantee resistance to corrosion, erosion, abrasion, or other sources of failure, nor does Seller guarantee a minimum length of service, or that the product shall be fit for any particular service. Seller warrants the products which it sells of other manufacturers to the extent of the warranties of their respective makers. Where engineering design or fabrication work is supplied, Buyer's acceptance of Seller's design or of delivery of work shall relieve Seller of all further obligation, other than as expressed in Seller's product warranty. THIS IS SELLER'S SOLE WARRANTY. SELLER MAKES NO OTHER WARRANTY OF ANY KIND, EXPRESSED OR IMPLIED, AND ALL IMPLIED WARRANTIES OF MERCHANTABILITY AND FITNESS FOR PARTICULAR PURPOSE WHICH EXCEED SELLER'S AFORESTATED OBLIGATION ARE HEREBY DISCLAIMED BY SELLER AND EXCLUDED FROM THIS WARRANTY. Seller neither assumes, nor authorizes any person to assume for it, any other obligation in connection with the sale of its engineering designs or products. This warranty shall not apply to any products or parts of products which (a) have been repaired or altered outside of Seller's factory, in any manner; or (b) have been subjected to misuse, negligence or accidents; or (c) have been used in a manner contrary to Sellers instructions or recommendations. Seller shall not be responsible for design errors due to inaccurate or incomplete information supplied on Valve Data Sheet(s) by Buyer or its representatives. The laws of the State of Maryland shall govern, apply and construe all questions and interpretations hereunder.

4. SELLER'S LIABILITY: Seller will not be liable for any loss, damage, cost of repairs, incidental or consequential damages of any kind, whether based upon warranty (except for the obligation accepted by Seller under "Warranty", above), contract or negligence arising in connection with the design, manufacture, sale, use or repair of the products or of engineering designs supplied by Buyer.

5. STORAGE: Valves shall be stored indoors free from job site dirt, mud, and temperature changes. If indoor storage is not possible, the valve must be stored above possible water or snow level and remain covered in the original shipping container. Failure to store valves in this fashion or to follow storage requirements for electrical components or other auxiliary equipment will void their warranty.

RETURNS: Seller cannot accept return of any products unless it has been issued a Returned Goods Authorization (RGA) number and form from RF Valves' Customer Service Dept. at (410) 850-4404 or email to Support@rfvalve.com.

All credits for returned goods are subject to the following: (a) All material returned must be clearly marked with the RGA#, and on its arrival at Seller's plant, be found to be in first-class condition; if not, cost of putting in salable condition will be deducted from credit memoranda; (b) a minimum \$50 or 5% handling charge will be made from all credit memoranda issued for material returned; (c) Transportation charges, if not prepaid, will be deducted from credit memoranda.

Credits, subject to above, apply only within 90 days after shipment.

i) 75% - standard manual/air release valve(s), in original packaging

ii) 50% - standard automated valve(s), in original packaging

iii) 75% - standard accessories unused

iv) Special purpose valve(s) or accessories designed to customer specifications returned for non-warranty reasons - credit determined on a case-by-case basis subject to inspection.

6. ORDER CANCELLATIONS or CHANGE ORDERS: Cancellations subject to the following charges as a percentage of total order amount; 10% order entered; 30% released for manufacture; 50% assembly in process or awaiting shipment, unless product is a non-standard, special purpose valve, in which case 100% or as agreed upon in writing case-by-case. Change Orders - Changing standard accessories, manufacturer's re-stocking fee, plus cost of new item(s). Change of valve structure or design from standard valve design or following release to manufacture, 25% of order; 50% of order when assembly in process or awaiting shipment, unless product a non-standard, special purpose valve, in which case agreed upon in writing on case-by-case basis.

7. SHIPMENTS: All products sent out will be carefully examined, counted and packed. The cost of any special packing or special handling caused by Buyer's requirements or requests shall be added to the amount of the order. No claim for shortages will be allowed unless made in writing within ten (10) days of receipt of shipment. Claims for products damaged or lost in transit should be made on the carrier, as Seller's responsibility ceases, and title passes, on delivery to the carrier.

8. SPECIAL PRODUCTS: Orders covering special or non-standard products are not subject to cancellation except on such terms as Seller may specify on application.

9. PRICES AND DESIGNS: Prices and designs are subject to change without notice. All prices are F.O.B. Point of Shipment, unless otherwise stated. In the absence of a special agreement, Buyer agrees to pay 1.5% monthly interest on all past due invoices. If Seller shall have any doubt at any time as to Buyer's financial responsibility, Seller may decline to make deliveries except of cash or satisfactory security.

10. TAXES: The amount of any sales, excise, or other taxes, if any, applicable to the products covered by this order, shall be added to the purchase price and shall be paid by Buyer unless Buyer provides Seller with an exemption certificate acceptable to the taxing authorities.

11. MINIMUM ORDER: \$500.00 plus transportation on complete valve assemblies. \$50 plus transportation on replacement spare parts.

12. TERMS: Cash, net 30 days unless otherwise specified

WARNING - RF Valves, Inc. VALVES ARE DESIGNED AND MANUFACTURED USING GOOD WORKMANSHIP AND MATERIALS, AND MEET INDUSTRY STANDARDS. THESE VALVES ARE AVAILABLE WITH COMPONENTS OF VARIOUS MATERIALS, AND THEY SHOULD BE USED ONLY IN SERVICES RECOMMENDED BY A COMPANY VALVE ENGINEER. MISAPPLICATION OF THE PRODUCT MAY RESULT IN INJURIES (INCLUDING DEATH) OR PROPERTY DAMAGE. A SELECTION OF VALVE COMPONENTS OF THE PROPER MATERIAL CONSISTENT WITH THE PARTICULAR PERFORMANCE REQUIREMENT IS IMPORTANT FOR PROPER APPLICATION. IF THE VALVE EXHIBITS ANY INDICATION OF LEAKAGE, DO NOT OPERATE. ISOLATE VALVE AND EITHER REPAIR OR REPLACE

Revised: April 2015

